

**S**  **FELOAD**™

**BUILT  
AFRICA  
TOUGH**

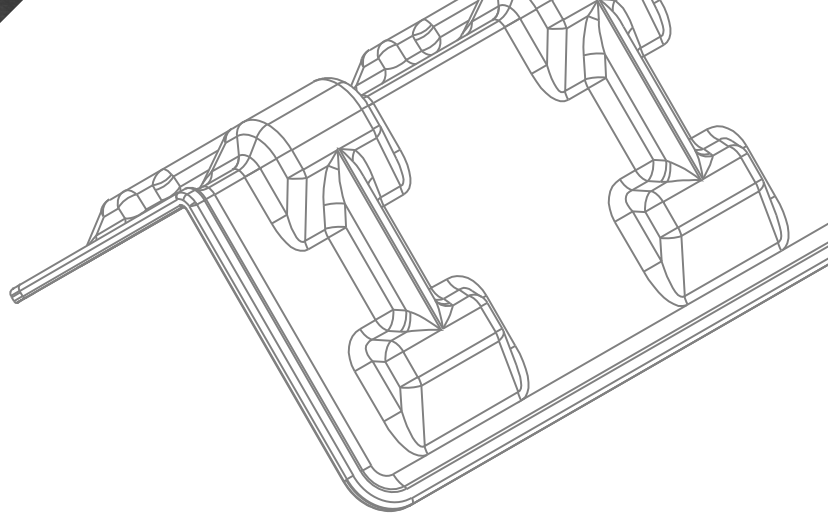

# WHY US

**As a global market leader in the development of high-quality safety products, we value and recognise changing needs and are constantly innovating, designing and manufacturing new products for the trucking and industrial sectors as well as the DIY enthusiasts, hobbyists, adventurers & tradesmen. Always with safety in mind.**

**As a brand of PIMMS Group, and having offices in the USA, Canada, UK and South Africa, we have access to leading industrial designers, engineers, tooling specialists and injection moulders. This ensures that the highest quality standards are always met and our innovative products always improve the lives of people.**

**Founded in South Africa in 2001, we partner with distributors globally to reach the world. People love our products because not only are they reliable, they are “Built Africa Tough”!**

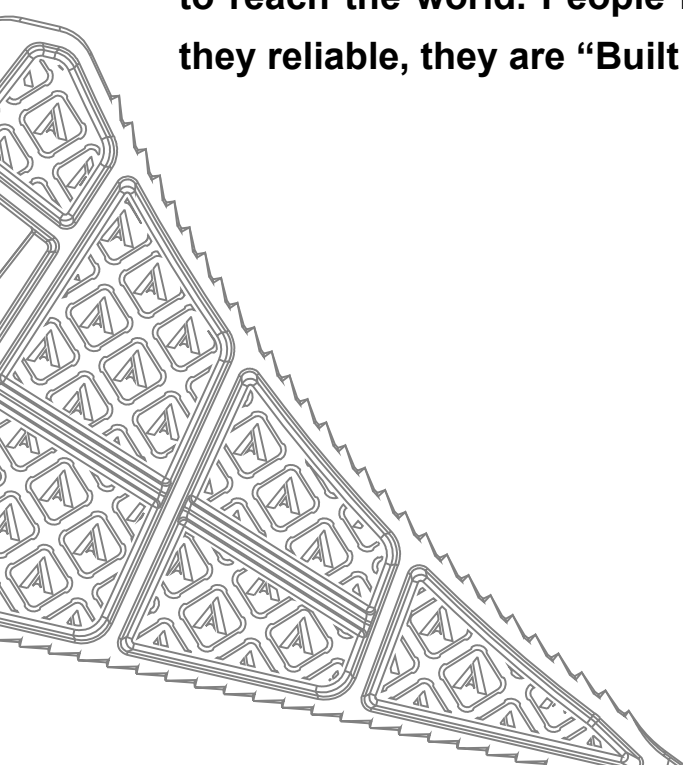

**ISO**  
9001:2015

**PIMMS** PLASTIC  
GROUP PRODUCT  
SPECIALISTS

# CORNER PROTECTORS

2.0 m

PROTECT YOUR GOODS  
WITH OUR DURABLE  
CORNER PROTECTORS

1.2 m

1.0 m

*Best  
Corner Protectors  
in SA*

## UNIQUE FEATURES

- ✓ Protects cargo by spreading the load of the tie-down strap
- ✓ Flexible enough to conform to different loads
- ✓ Strong enough to bend, not break

# IT'S MORE THAN TOUGH

## SPECIFICATIONS

100 mm	0.10 kg
300 mm	0.75 kg
600 mm	1.2 kg
1 m	2 kg
1.2 m	2.2 kg
2 m	3.5 kg
Material	Polypropylene
Standard Colours	Yellow, Blue, Green, Red & Black
	Other Colours on pre-order

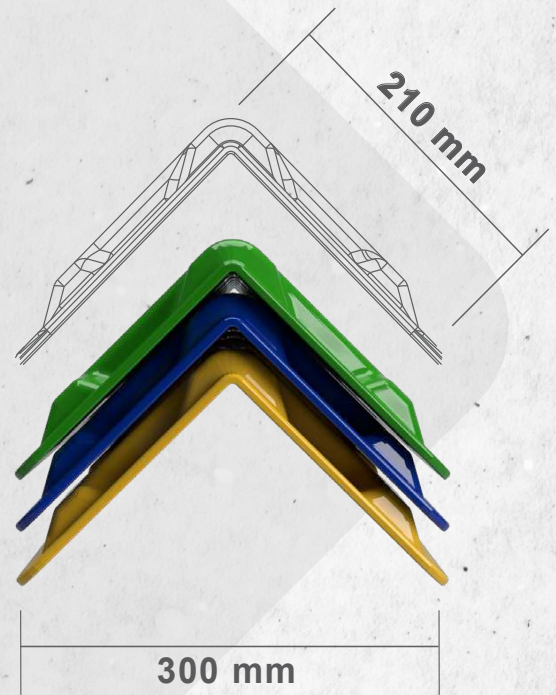

100 mm

300 mm

600 mm

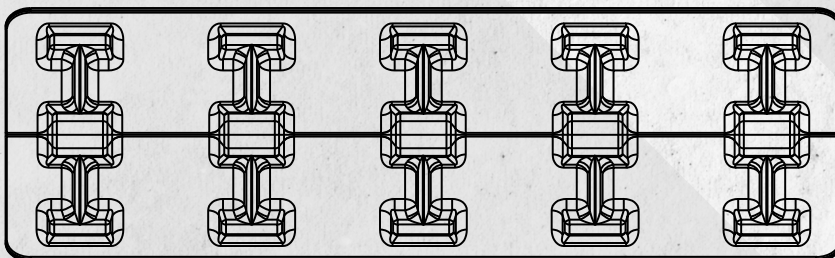
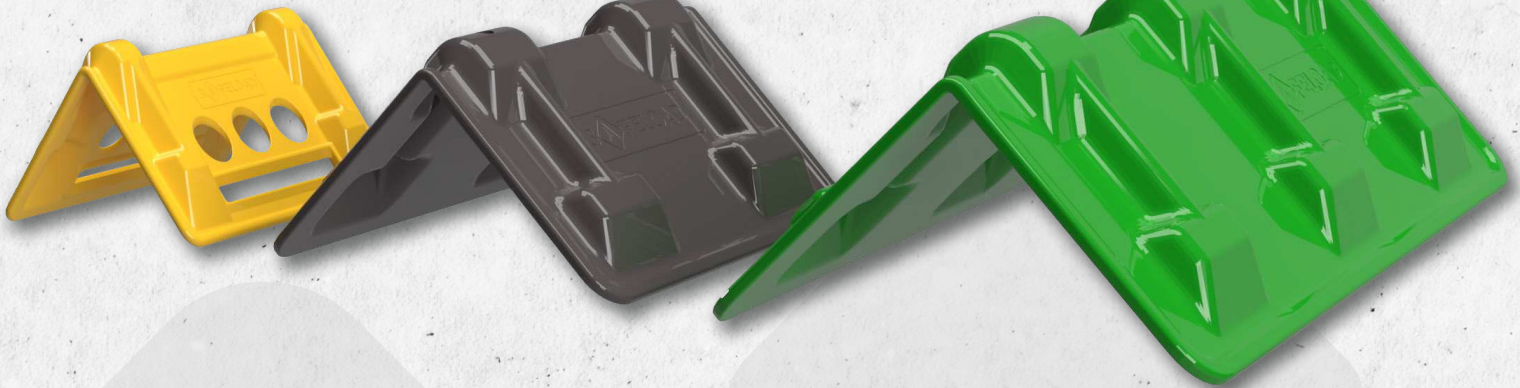

300 mm

## SIZES

2.0 m  
1.2 m  
1.0 m  
600 mm  
300 mm  
100 mm

# RATCHETS & STRAPS

**QUICK RELEASE  
MECHANISM**



## SPECIFICATIONS

Sizes	Ratchet with 50 mm x 9 m strap & J-Hook (5 ton)
	Ratchet with 50 mm x 6 m strap & J-Hook (2 ton)
Colour	Standard - Yellow Other colours on pre-order

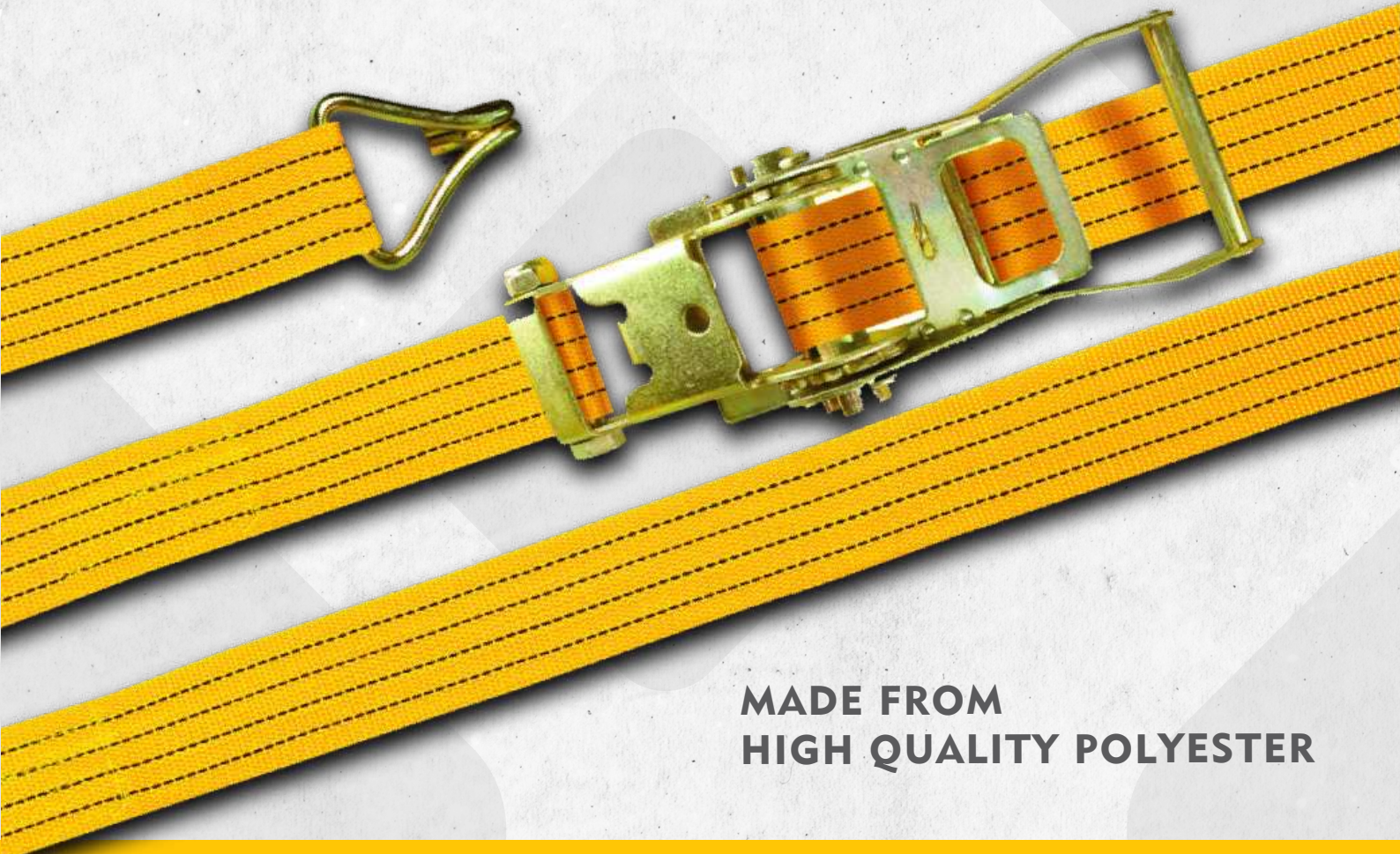

**MADE FROM  
HIGH QUALITY POLYESTER**

# MIGHTY CHOCKS

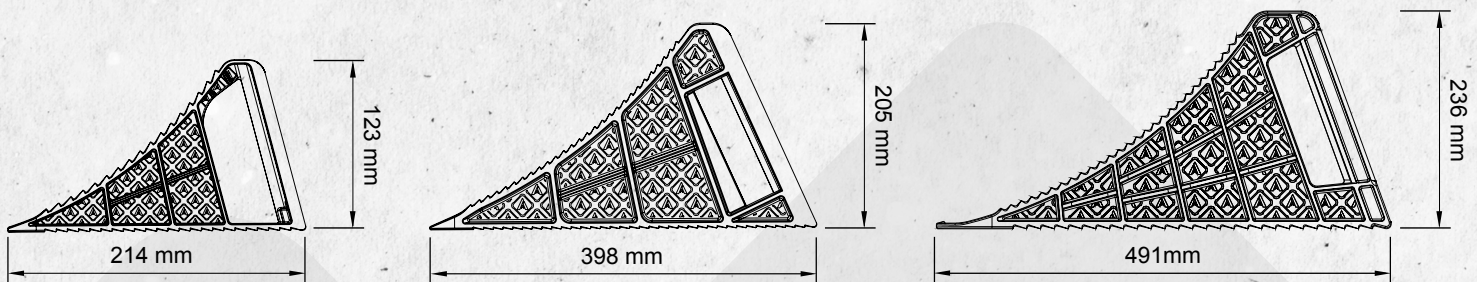
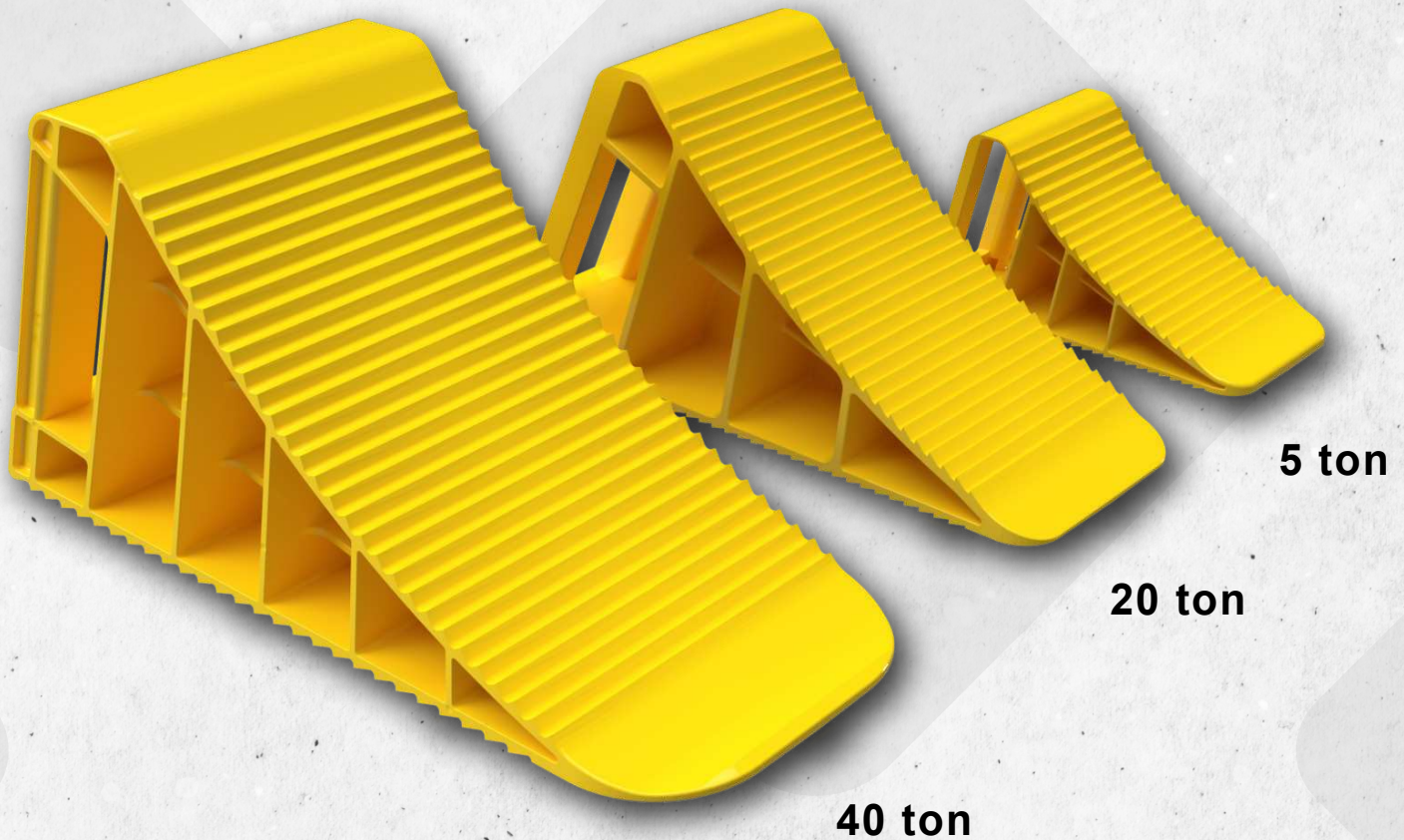

## UNIQUE FEATURES

- ✓ Sold in pairs for loads of up to 5 ton, 20 ton & 40 ton
- ✓ Serrated edges for maximum grip
- ✓ Easy grip handle for effortless handling
- ✓ Optimal structure for weight bearing capability, yet lightweight

## SPECIFICATIONS

5 ton	0.3 kg
20 ton	1.2 kg
40 ton	1.7 kg
Material	Polypropylene
Colour	Yellow

**OPTIONAL CARRIER  
AVAILABLE**

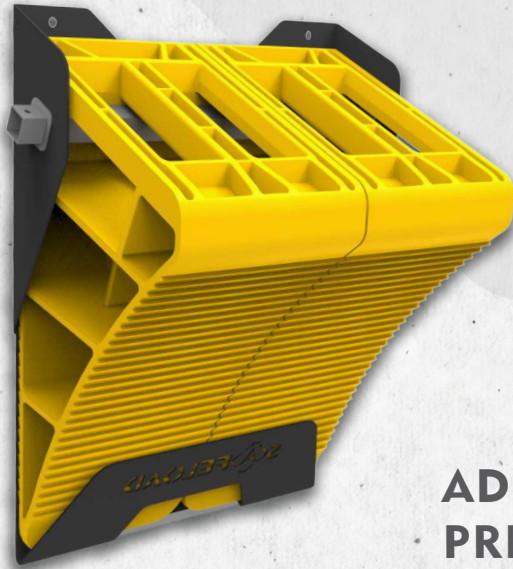

**ADDED SECURITY TO  
PREVENT TRUCKS &  
TRAILERS FROM ROLLING**

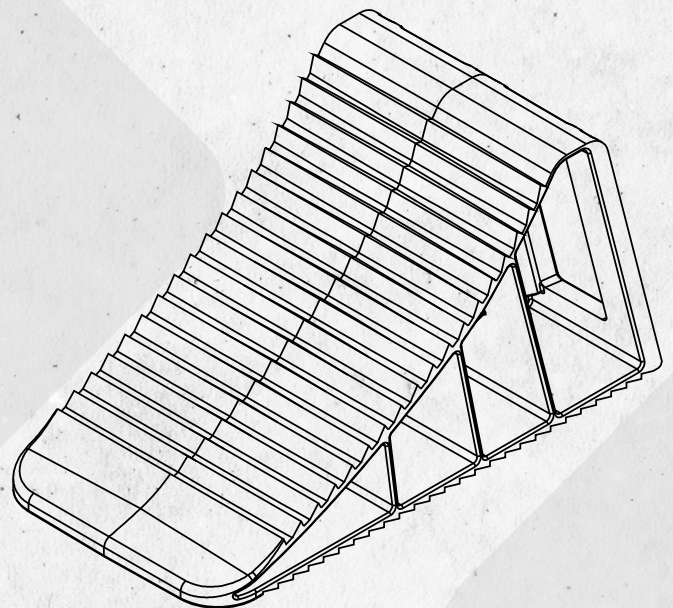

# WHEEL NUT INDICATORS

## OPEN CAPS

### SIZES

17 mm - 57 mm



## DUST CAPS

### SIZES

17 mm - 41 mm

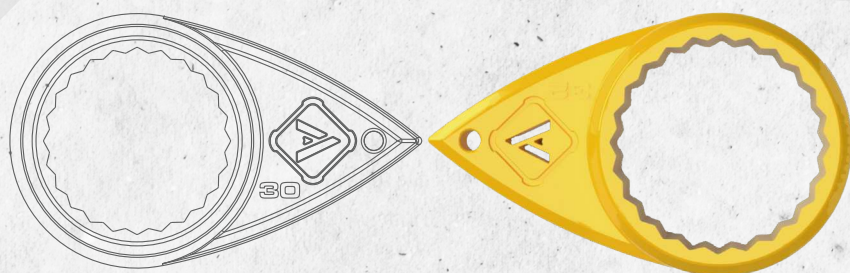

## SPECIFICATIONS

Open Caps	17 mm - 57 mm
Dust Caps	17 mm - 41 mm (Actual product may vary)
Colours	Standard - Yellow Other colours on pre-order

## UNIQUE FEATURES

- ✓ Time saver for driver
- ✓ Visual indicator
- ✓ Safety requirement for entry into mines





# DURATOUGH BOX 120L



**IDEAL LOCKABLE BOX  
TO STORE & TRANSPORT  
THE THINGS THAT MATTER**

## **UNIQUE FEATURES**

- ✓ Rain/water resistant
- ✓ Strong & durable
- ✓ Mountable for walls & vehicles
- ✓ Secure compression latches
- ✓ Lockable heavy-duty latches
- ✓ Ergonomic pull handle
- ✓ Wheels for easy maneuverability



# OPTIONAL MOUNTING CONFIGURATIONS

(PURCHASED SEPARATELY)

## PERMANENT SYSTEM



## REMOVABLE SYSTEM



## SPECIFICATIONS

Weight	11 kg (without content)
Volume	120 L
Material	Polypropylene
Colour	Black

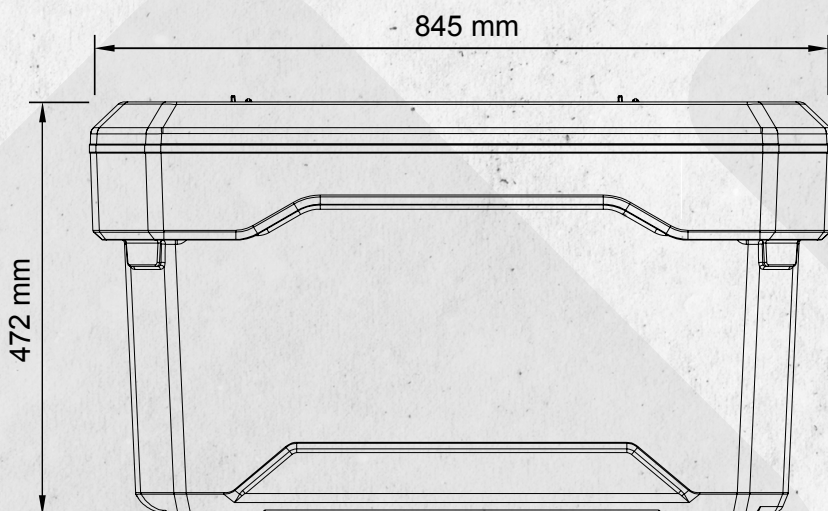
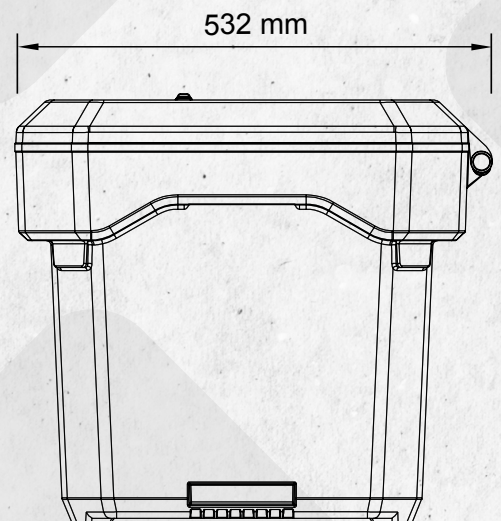

# DURATOUGH BOX 150L



## SPECIFICATIONS

Weight	+/-9.6kg (without content)
Volume	150 L
Material	Polypropylene
Colour	Black



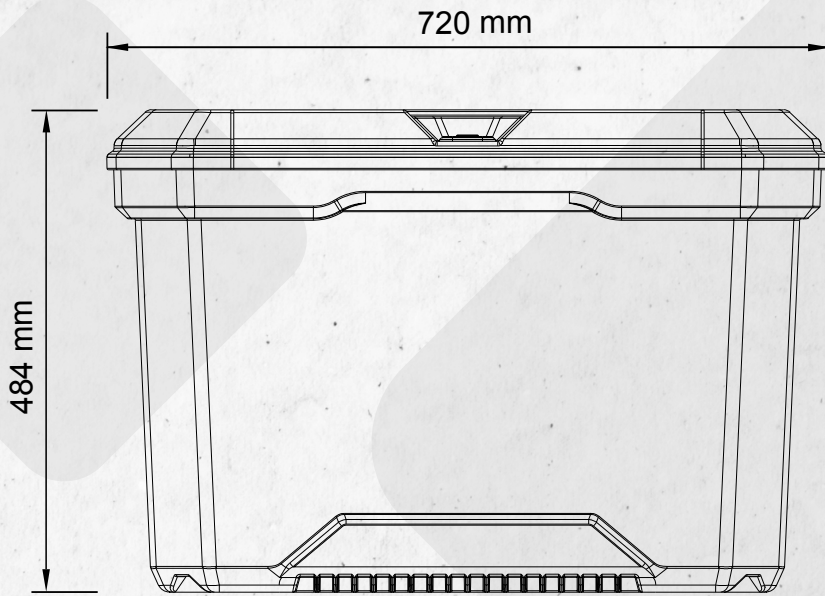

**IDEAL LOCKABLE BOX  
TO STORE & TRANSPORT  
THE THINGS THAT MATTER**

## **UNIQUE FEATURES**

- ✓ Rain/water resistant
- ✓ Strong & durable
- ✓ Mountable for walls & vehicles
- ✓ Secure compression latches
- ✓ Lockable heavy-duty latches

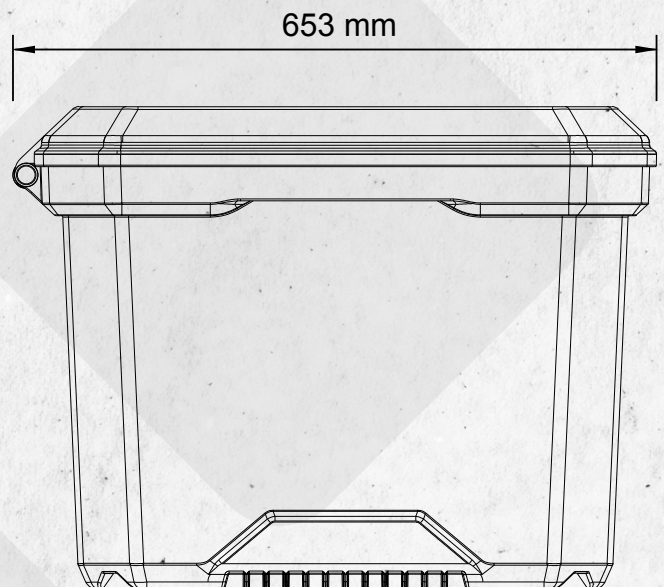

# MAXI PRO 700 TOOLBOX



## UNIQUE FEATURES

- ✓ Durable & heavy duty
- ✓ Removable handy organiser tray
- ✓ Deep enough to store power tools
- ✓ Robust lid clips
- ✓ Padlock tab for locking

MADE TOUGH TO HANDLE  
ALL TYPES OF EQUIPMENT

LARGE ENOUGH TO STORE  
PLENTY TOOLS & GEAR

## SPECIFICATIONS

Box weight	4 kg (without content)
Volume	32 L
Material	Polypropylene
Content use	For DIY & heavy-duty tools
Colour	Various

AVAILABLE COLOURS





## ORGANISER TRAY INCLUDED



## CLEAR REPLACEMENT FLAPS

✓ Replacement flaps sold separately

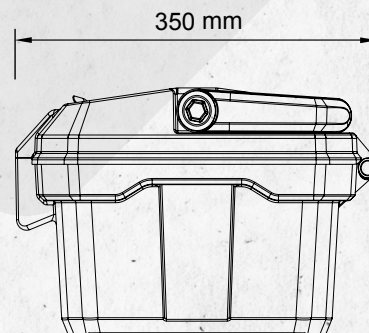
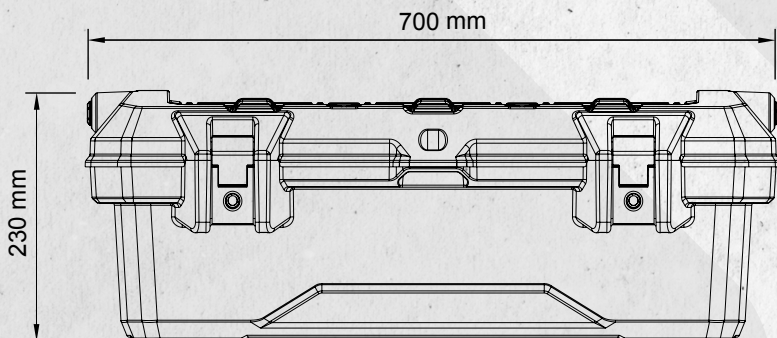

# MAXI PRO 500 TOOLBOX WITH ORGANISER TRAY



## SPECIFICATIONS

Box weight	3 kg (without content)
Volume	25 L
Material	Polypropylene
Colour	Various

## UNIQUE FEATURES (TOOLBOX)

- ✓ Deep for power tools
- ✓ Removable tray with handle
- ✓ Padlock tab

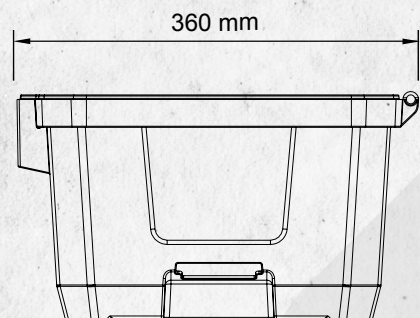
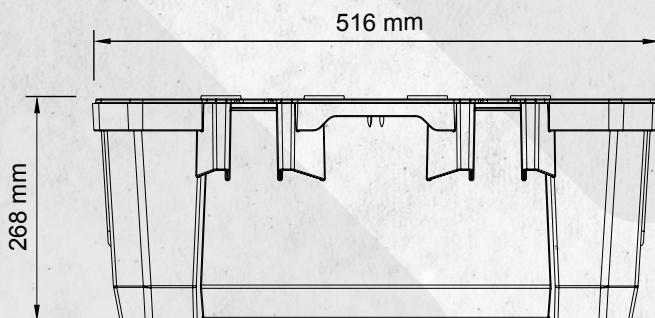



## ORGANISER TRAY UNIQUE FEATURES

- ✓ Stackable
- ✓ Clips onto toolbox
- ✓ Arrange dividers to fit your needs

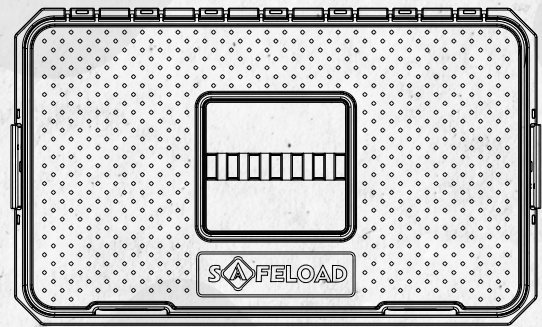



# ACCESSORIES

## ADDITIONAL & STACKABLE ORGANISER TRAYS



## CLEAR REPLACEMENT FLAPS

✓ Replacement flaps sold in pairs



## DIVIDERS

✓ Spare dividers sold separately

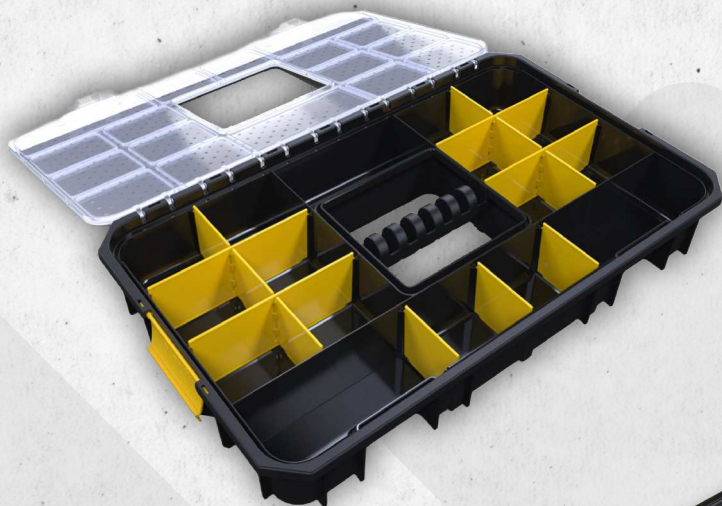

## WHITEBOARD

✓ Whiteboard sold separately



# FIRE EXTINGUISHER BOXES



R&B



R&C

## UNIQUE FEATURES:

- ✓ Non corrosive and weather resistant
- ✓ Padlock/Security seal tab
- ✓ Inspection window
- ✓ Strong enough to mount on the vehicle with a 9kg bottle



R&R

## SPECIFICATIONS

Box weight	4 kg (without content)
Volume	32 L
Material	Polypropylene
Colour	R&B, R&C, R&R

**EXCLUDES  
FIRE EXTINGUISHER**

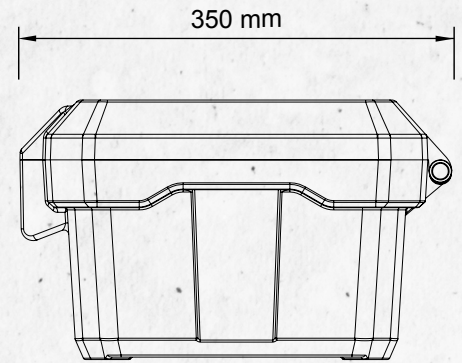
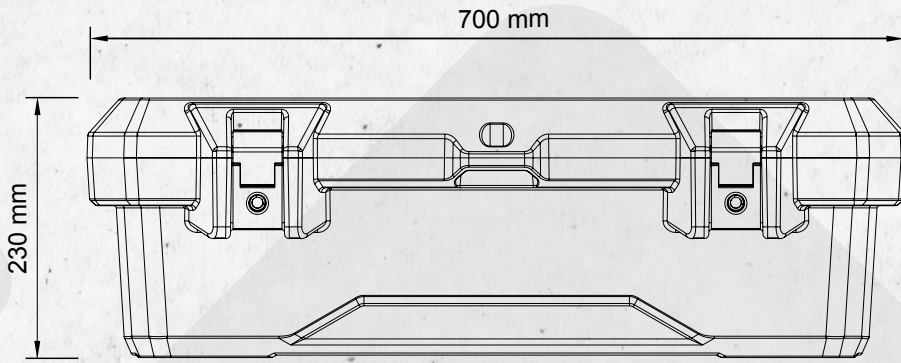

**QUICK ACCESS  
& SAFE STORAGE**

**OPEN CRADLE  
FIRE BRACKET**

**UNIQUE FEATURES:**

- ✓ Quick access and easy to use
- ✓ Quick release and durable securing straps
- ✓ Wall or vehicle mountable



# MEDICAL BOXES

## WALL MOUNTED MEDICAL BOX WITH REMOVABLE INNER BACKPACK



## WALL MOUNTED MEDICAL BOX (BOX ONLY)

### SPECIFICATIONS

Box weight	4 kg (without content)
Volume	32 L
Material	Polypropylene
Colour	Green base with clear lid or white lid

### UNIQUE FEATURES:

- ✓ Durable
- ✓ weather resistant (UV resistant)
- ✓ Padlock tab
- ✓ Wall or vehicle mountable

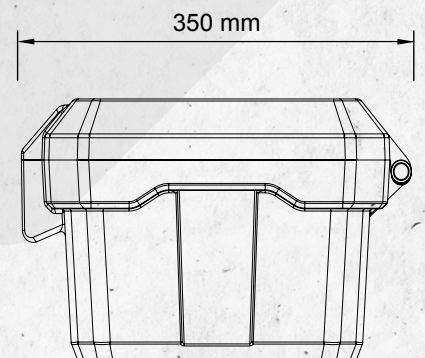
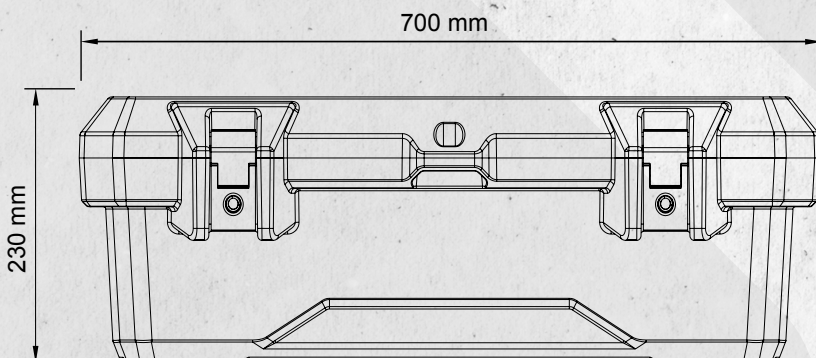

# F16 DUST MASK

**IDEAL FOR  
PROVIDING PROTECTION  
FROM DUST & TOXIC  
AIRBORNE HAZARDS**

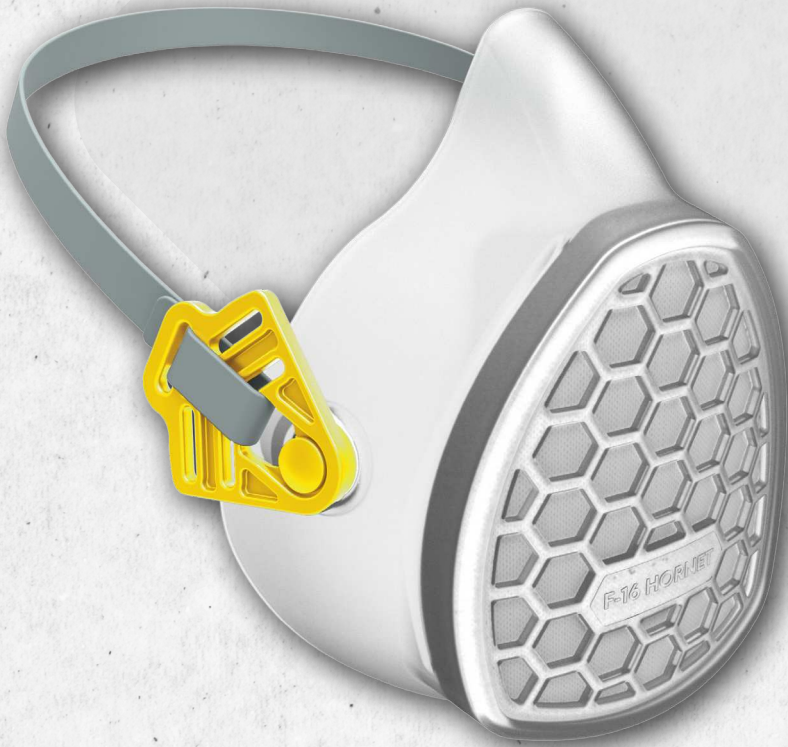

## **UNIQUE FEATURES**

- ✓ 100% Reusable
- ✓ Replaceable filter
- ✓ Ergonomically designed
- ✓ Available in sizes Medium & Large

## **SPECIFICATIONS**

<b>Material</b>	<b>Soft material</b>
<b>Filter info</b>	<b>ISO 14644-1:2015 certified</b>



# STEAM STERILIZATION CONTAINER

- ✓ Polypropylene container to sterilize the mask
- ✓ Suitable for microwaving



## COLOUR OPTIONS



## 3 DIFFERENT STRAP WEAR CONFIGURATIONS



# HAND DISPENSER



**PUSH**



**DISPENSE**

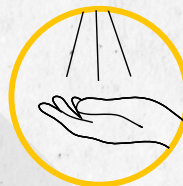

**CLEAN**



**SANITISER REFILLS  
AVAILABLE**

## SPECIFICATIONS

**Material**

**ABS**

## UNIQUE FEATURES

- ✓ 700 ml Refillable bottle
- ✓ Easy push mechanism
- ✓ Easy to mount design.

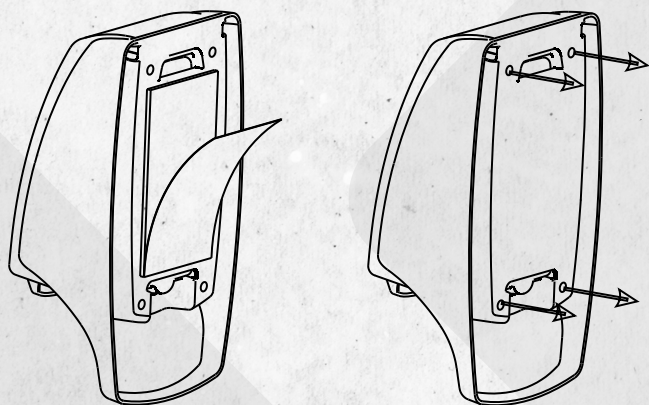

**DOUBLE SIDED TAPE &  
SCREW MOUNTING OPTIONS**



# CARABINER



## UNIQUE FEATURES

- ✓ Easy to clip to belt and/or to hold your keys
- ✓ Built in mini-ruler
- ✓ Built in sharp edge to open boxes/sellotape
- ✓ 2x opening feet to place your phone
- ✓ 5kg carrying capacity

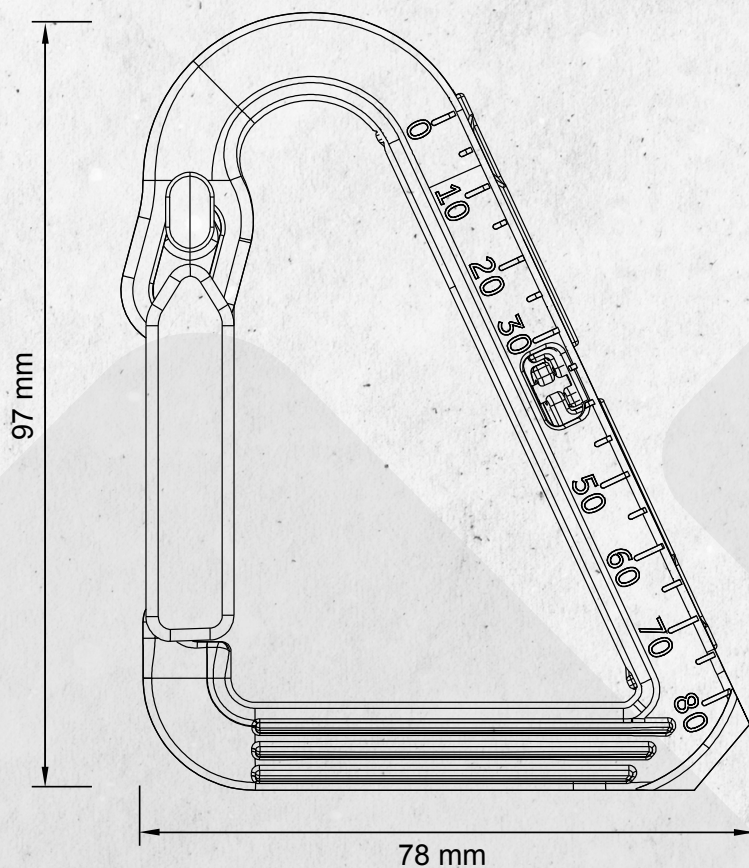

## SPECIFICATIONS

Size	97 mm x 78 mm)
Material	Acetal
Colour	Yellow & Black



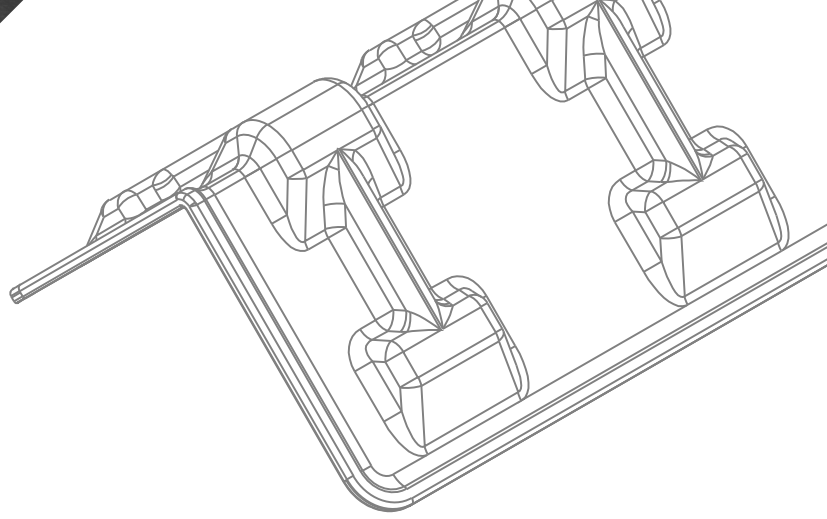

# LET'S CONNECT

**T:** +2711 7084755

**E:** [sales@safeload.co.za](mailto:sales@safeload.co.za)

**A:** 1050 Liner Ave, Corner Zeiss Road, Laser Park, Honeydew,  
Johannesburg, South Africa

**Opening hours | Mon - Thur 8:00 - 17:00 | Fri 8:00 - 15:00**

