

S  **FELOAD**™

**BUILT
AFRICA
TOUGH**

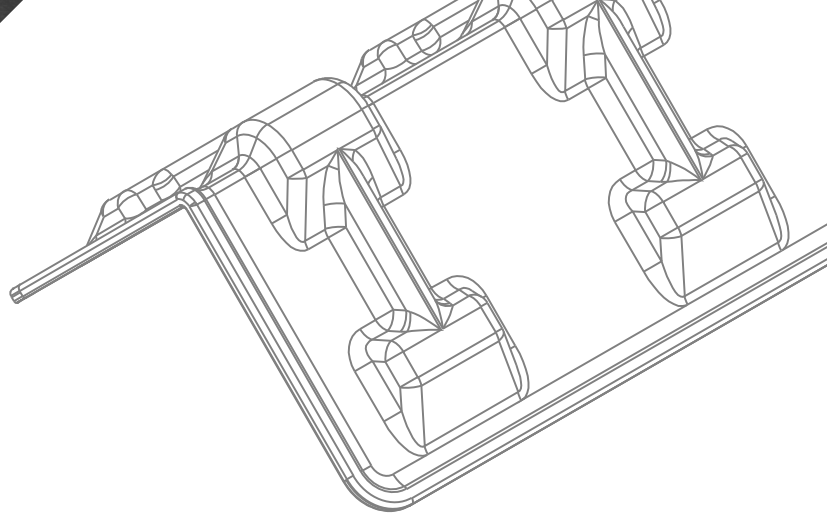

WHY US

As a global market leader in the development of high-quality safety products, we value and recognise changing needs and are constantly innovating, designing and manufacturing new products for the trucking and industrial sectors as well as the DIY enthusiasts, hobbyists, adventurers & tradesmen. Always with safety in mind.

As a brand of PIMMS Group, and having offices in the USA, Canada, UK and South Africa, we have access to leading industrial designers, engineers, tooling specialists and injection moulders. This ensures that the highest quality standards are always met and our innovative products always improve the lives of people.

Founded in South Africa in 2001, we partner with distributors globally to reach the world. People love our products because not only are they reliable, they are “Built Africa Tough”!

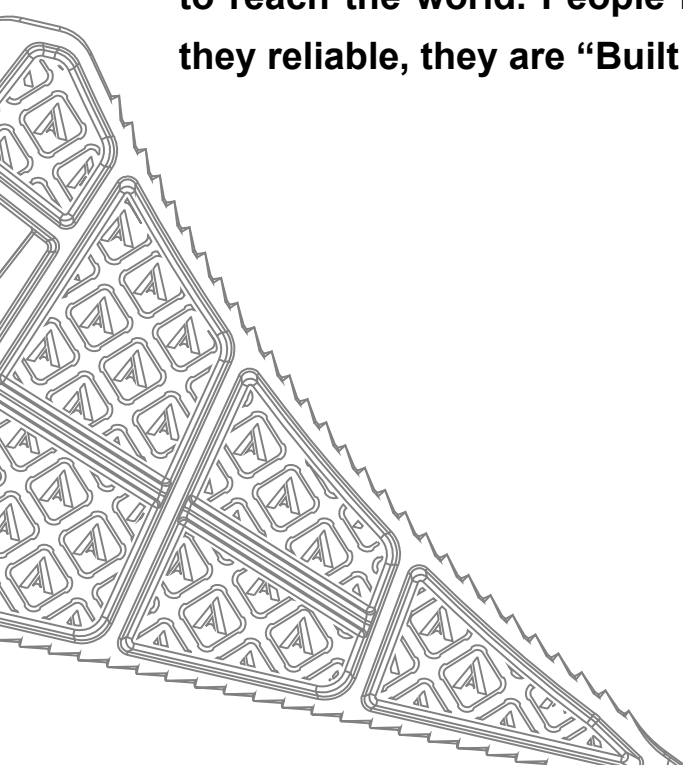

ISO
9001:2015

PIMMS PLASTIC
GROUP PRODUCT
SPECIALISTS

CORNER PROTECTORS

2.0 m

PROTECT YOUR GOODS
WITH OUR DURABLE
CORNER PROTECTORS

1.2 m

1.0 m

*Best
Corner Protectors
in SA*

UNIQUE FEATURES

- ✓ Protects cargo by spreading the load of the tie-down strap
- ✓ Flexible enough to conform to different loads
- ✓ Strong enough to bend, not break

IT'S MORE THAN TOUGH

SPECIFICATIONS

100 mm	0.10 kg
300 mm	0.75 kg
600 mm	1.2 kg
1 m	2 kg
1.2 m	2.2 kg
2 m	3.5 kg
Material	Polypropylene
Standard Colours	Yellow, Blue, Green, Red & Black
	Other Colours on pre-order

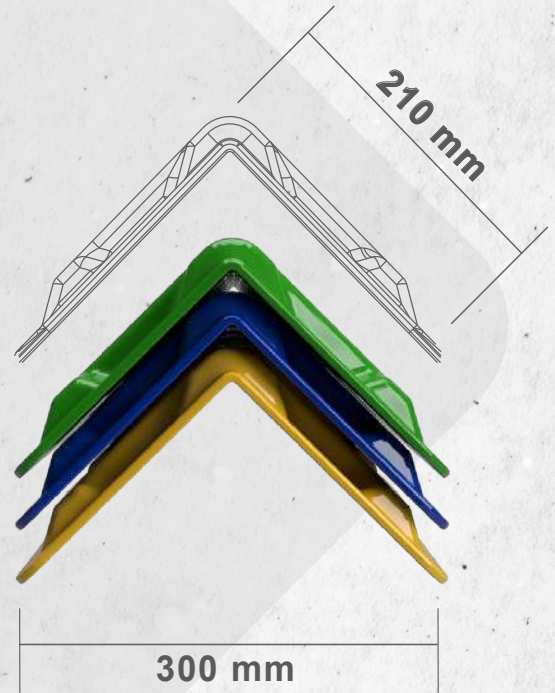

100 mm

300 mm

600 mm

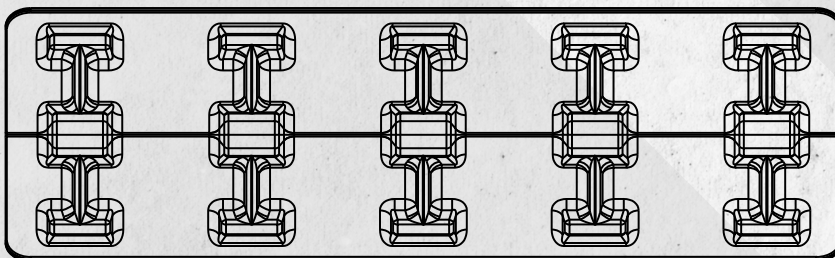
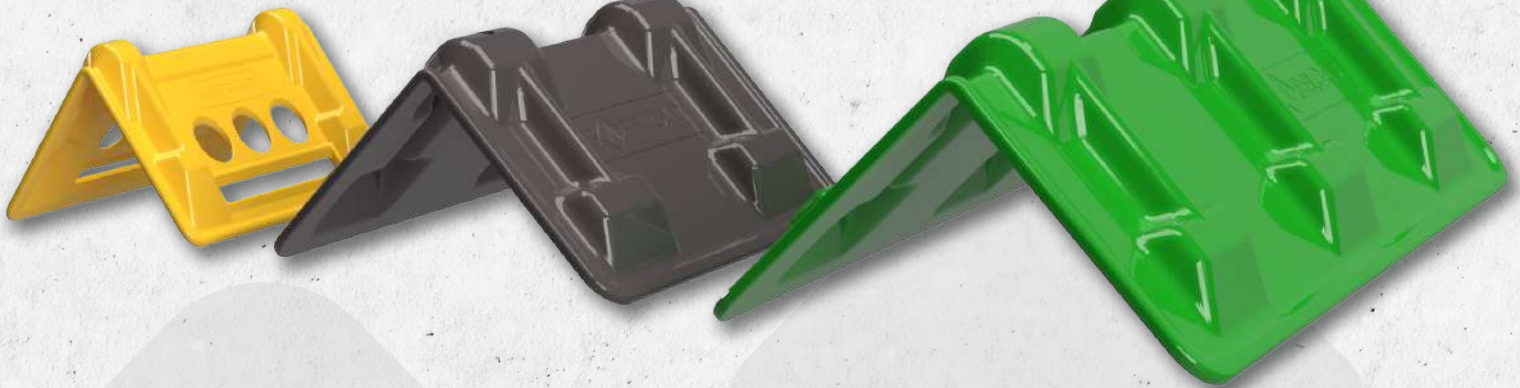

300 mm

SIZES

2.0 m
1.2 m
1.0 m
600 mm
300 mm
100 mm

RATCHETS & STRAPS

**QUICK RELEASE
MECHANISM**



SPECIFICATIONS

Sizes	Ratchet with 50 mm x 9 m strap & J-Hook (5 ton)
	Ratchet with 50 mm x 6 m strap & J-Hook (2 ton)
Colour	Standard - Yellow Other colours on pre-order

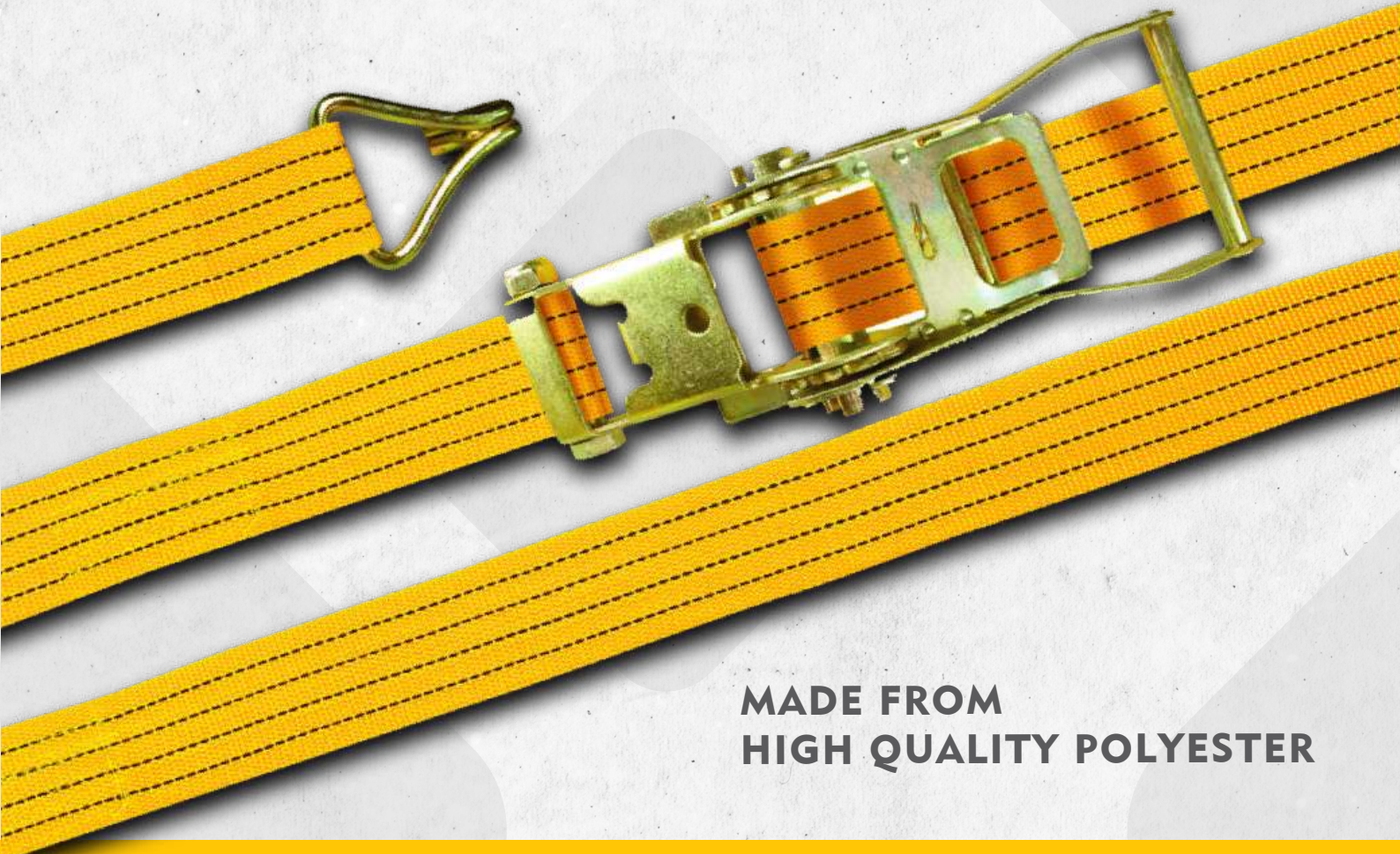

**MADE FROM
HIGH QUALITY POLYESTER**

MIGHTY CHOCKS

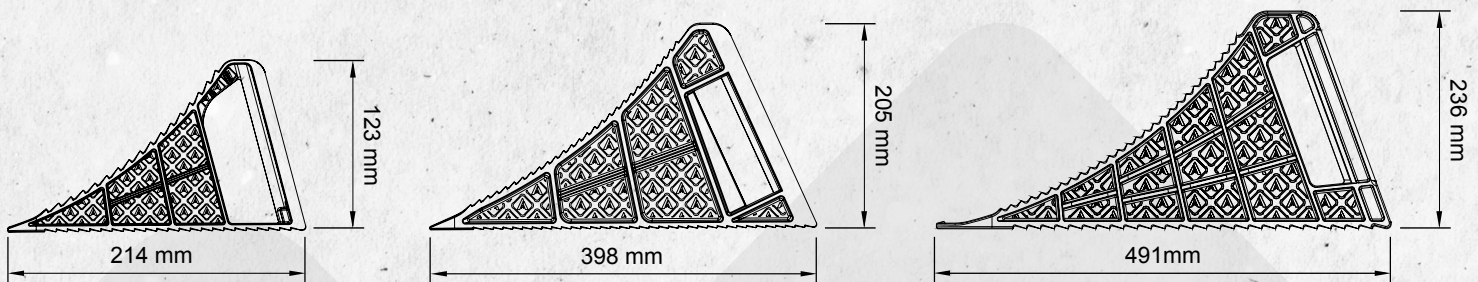
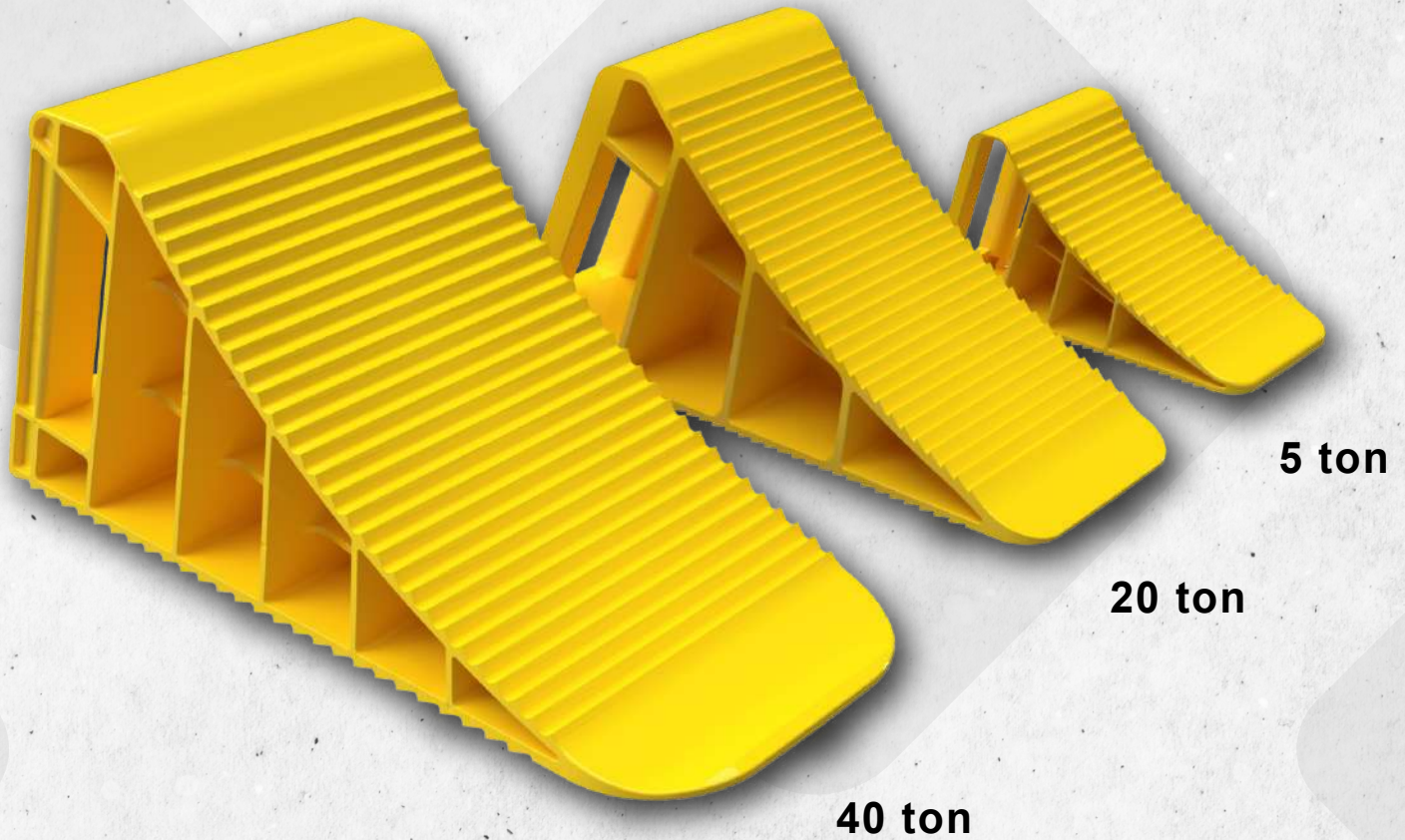

UNIQUE FEATURES

- ✓ Sold in pairs for loads of up to 5 ton, 20 ton & 40 ton
- ✓ Serrated edges for maximum grip
- ✓ Easy grip handle for effortless handling
- ✓ Optimal structure for weight bearing capability, yet lightweight

SPECIFICATIONS

5 ton	0.3 kg
20 ton	1.2 kg
40 ton	1.7 kg
Material	Polypropylene
Colour	Yellow

**OPTIONAL CARRIER
AVAILABLE**

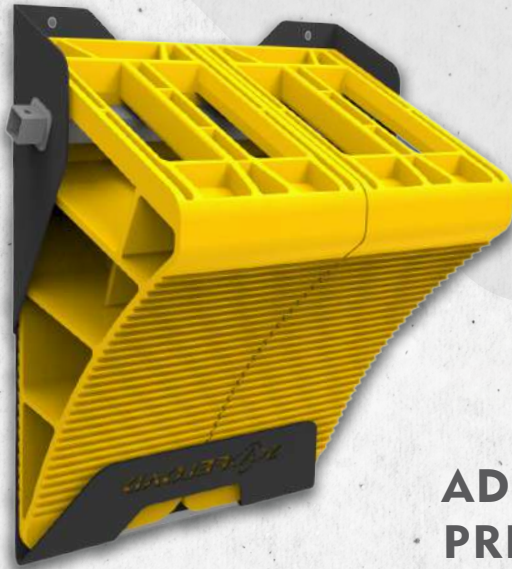

**ADDED SECURITY TO
PREVENT TRUCKS &
TRAILERS FROM ROLLING**

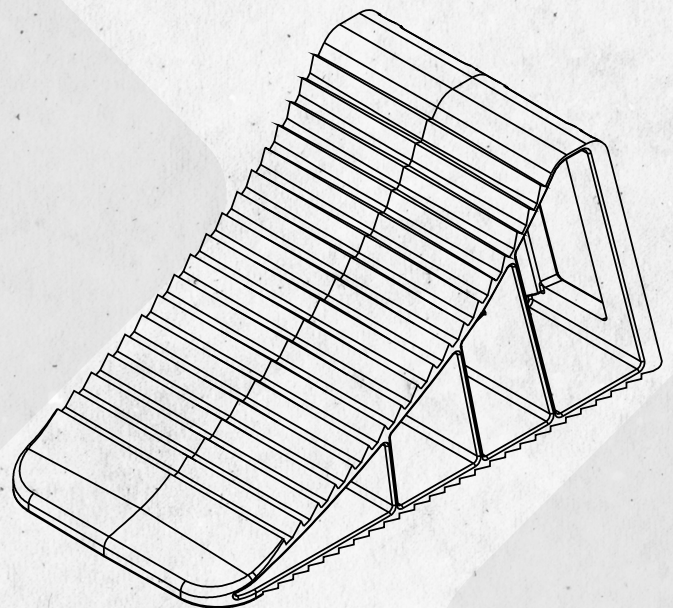

WHEEL NUT INDICATORS

OPEN CAPS

SIZES

17 mm - 57 mm



DUST CAPS

SIZES

17 mm - 41 mm

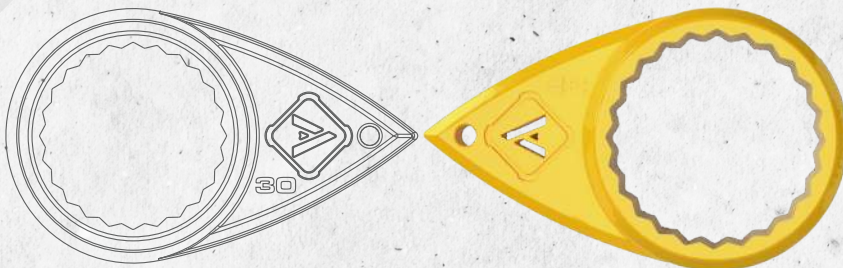

SPECIFICATIONS

Open Caps	17 mm - 57 mm
Dust Caps	17 mm - 41 mm (Actual product may vary)
Colours	Standard - Yellow Other colours on pre-order

UNIQUE FEATURES

- ✓ Time saver for driver
- ✓ Visual indicator
- ✓ Safety requirement for entry into mines

DURATOUGH BOX 120L



**IDEAL LOCKABLE BOX
TO STORE & TRANSPORT
THE THINGS THAT MATTER**

UNIQUE FEATURES

- ✓ Rain/water resistant
- ✓ Strong & durable
- ✓ Mountable for walls & vehicles
- ✓ Secure compression latches
- ✓ Lockable heavy-duty latches
- ✓ Ergonomic pull handle
- ✓ Wheels for easy maneuverability



OPTIONAL MOUNTING CONFIGURATIONS

(PURCHASED SEPARATELY)

PERMANENT SYSTEM



REMOVABLE SYSTEM



SPECIFICATIONS

Weight	11 kg (without content)
Volume	120 L
Material	Polypropylene
Colour	Black

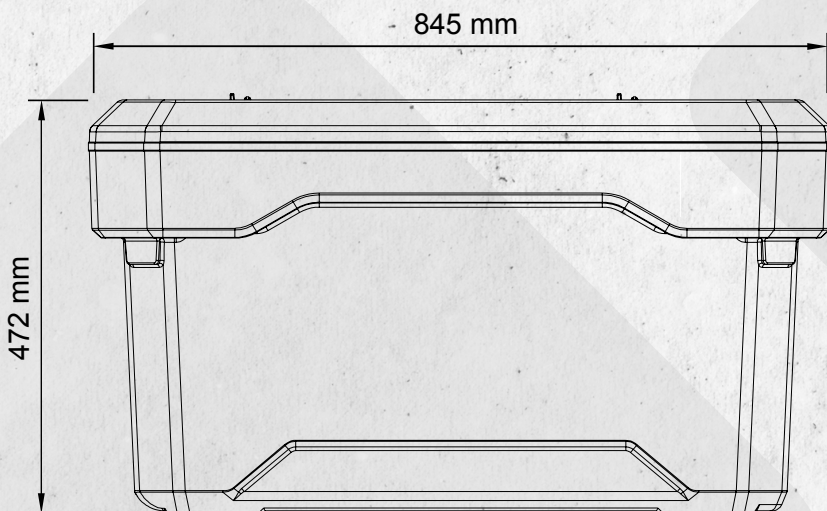
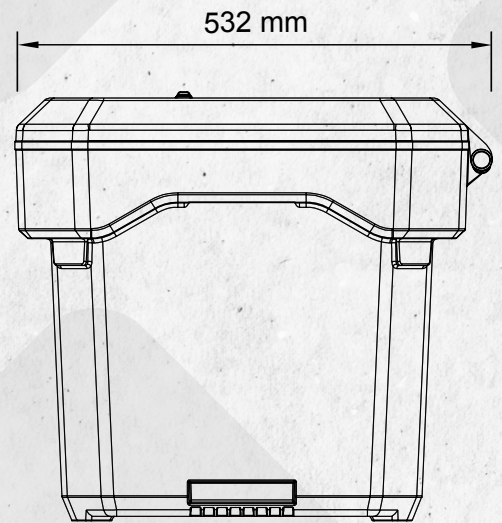

DURATOUGH BOX 150L



SPECIFICATIONS

Weight	+/-9.6kg (without content)
Volume	150 L
Material	Polypropylene
Colour	Black



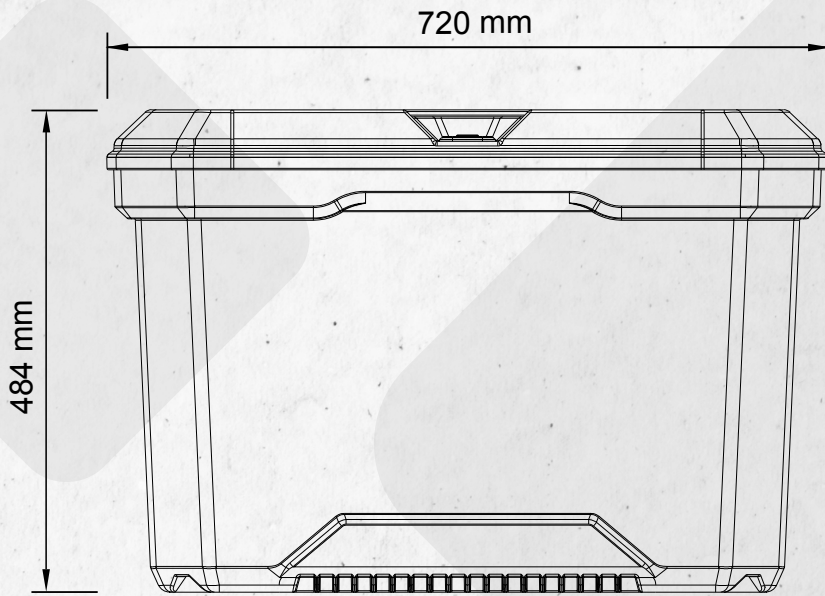

**IDEAL LOCKABLE BOX
TO STORE & TRANSPORT
THE THINGS THAT MATTER**

UNIQUE FEATURES

- ✓ Rain/water resistant
- ✓ Strong & durable
- ✓ Mountable for walls & vehicles
- ✓ Secure compression latches
- ✓ Lockable heavy-duty latches

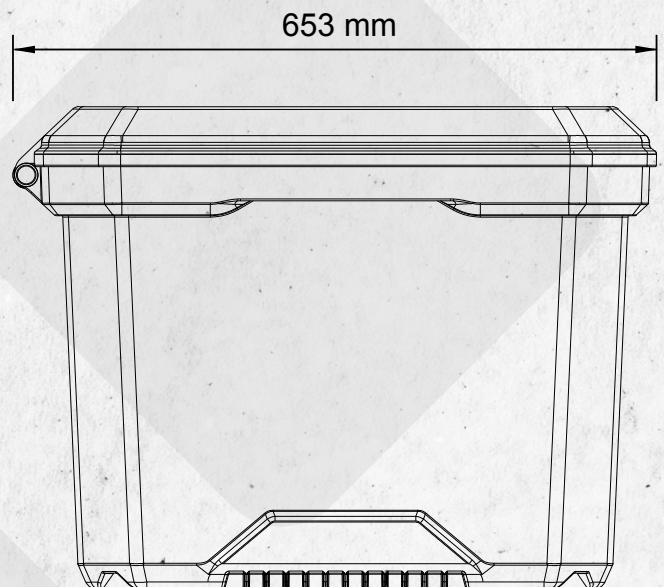

MAXI PRO 700 TOOLBOX



UNIQUE FEATURES

- ✓ Durable & heavy duty
- ✓ Removable handy organiser tray
- ✓ Deep enough to store power tools
- ✓ Robust lid clips
- ✓ Padlock tab for locking

MADE TOUGH TO HANDLE
ALL TYPES OF EQUIPMENT

LARGE ENOUGH TO STORE
PLENTY TOOLS & GEAR

SPECIFICATIONS

Box weight	4 kg (without content)
Volume	32 L
Material	Polypropylene
Content use	For DIY & heavy-duty tools
Colour	Various

AVAILABLE COLOURS





ORGANISER TRAY INCLUDED



CLEAR REPLACEMENT FLAPS

✓ Replacement flaps sold separately

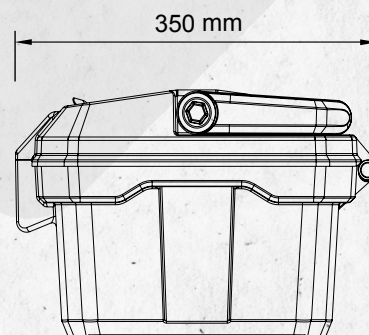
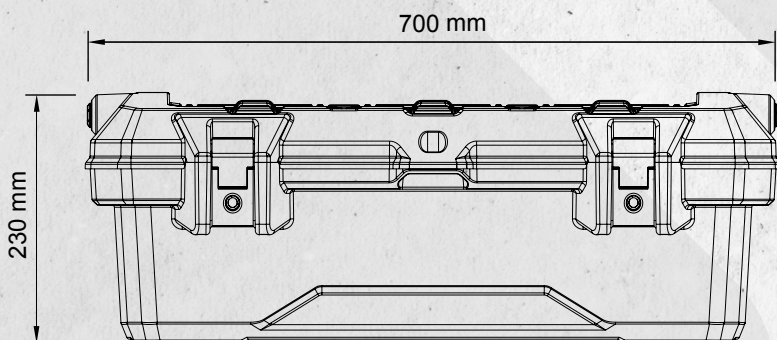

MAXI PRO 500 TOOLBOX WITH ORGANISER TRAY



SPECIFICATIONS

Box weight	3 kg (without content)
Volume	25 L
Material	Polypropylene
Colour	Various

UNIQUE FEATURES (TOOLBOX)

- ✓ Deep for power tools
- ✓ Removable tray with handle
- ✓ Padlock tab

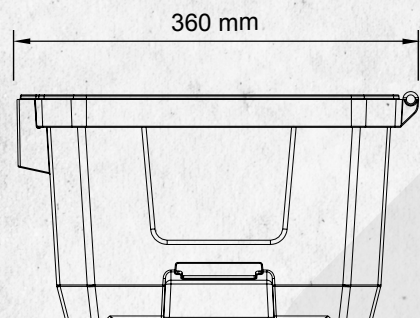
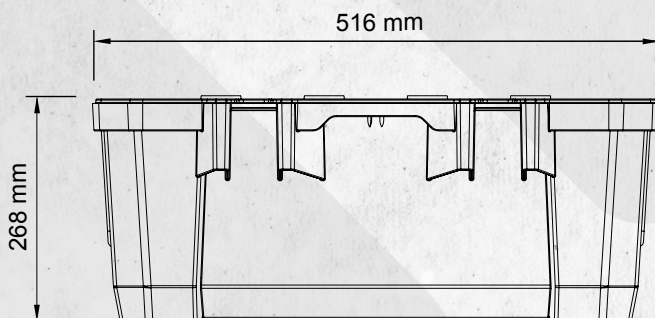



ORGANISER TRAY UNIQUE FEATURES

- ✓ Stackable
- ✓ Clips onto toolbox
- ✓ Arrange dividers to fit your needs

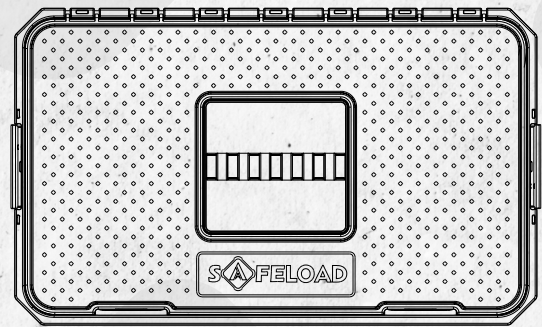

ACCESSORIES

ADDITIONAL & STACKABLE ORGANISER TRAYS



CLEAR REPLACEMENT FLAPS

✓ Replacement flaps sold separately



DIVIDERS

✓ Spare dividers sold separately

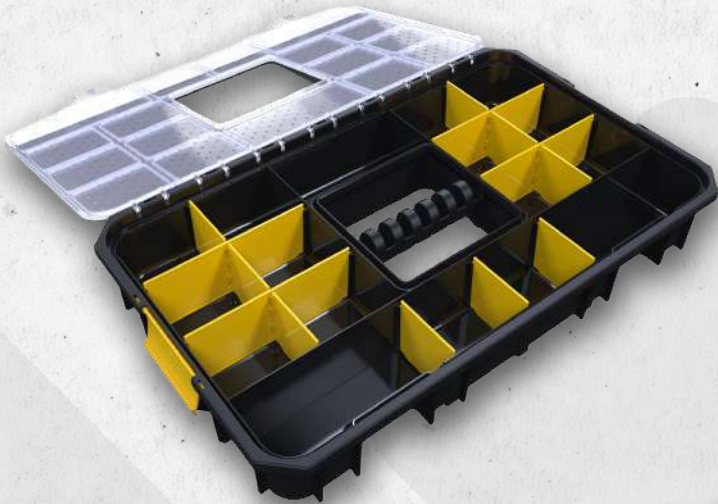

WHITEBOARD

✓ Whiteboard sold separately



STORAGE BINS & MOUNTING PANELS



SPECIFICATIONS

BIN 2:	135mm x 105mm x 75mm
BIN 3:	190mm x 105mm x 75mm
BIN 4:	210mm x 140mm x 130mm
BIN 5:	280mm x 140mm x 130mm
BIN 6:	280mm x 210mm x 180mm
BIN 7:	375mm x 210mm x 180mm
BIN 8:	375mm x 420mm x 180mm
Colours:	Black, Blue, Clear, Green, Grey, Red & Yellow
Material:	PRP1042 Polypropylene co-polymers

UNIQUE FEATURES

- ✓ Ideal space saving solution
- ✓ Bins are stackable
- ✓ Dividers are available for each size
- ✓ Bins can be mounted onto panels
- ✓ 7 sizes available

OFFERING TAILORED STORAGE SOLUTIONS. EASILY MOUNTABLE ON THE WALL AND FEATURING DIVIDERS FOR FURTHER CUSTOMIZATION.



WALL MOUNTED STEEL PANELS

(PANELS SOLD SEPARATELY)

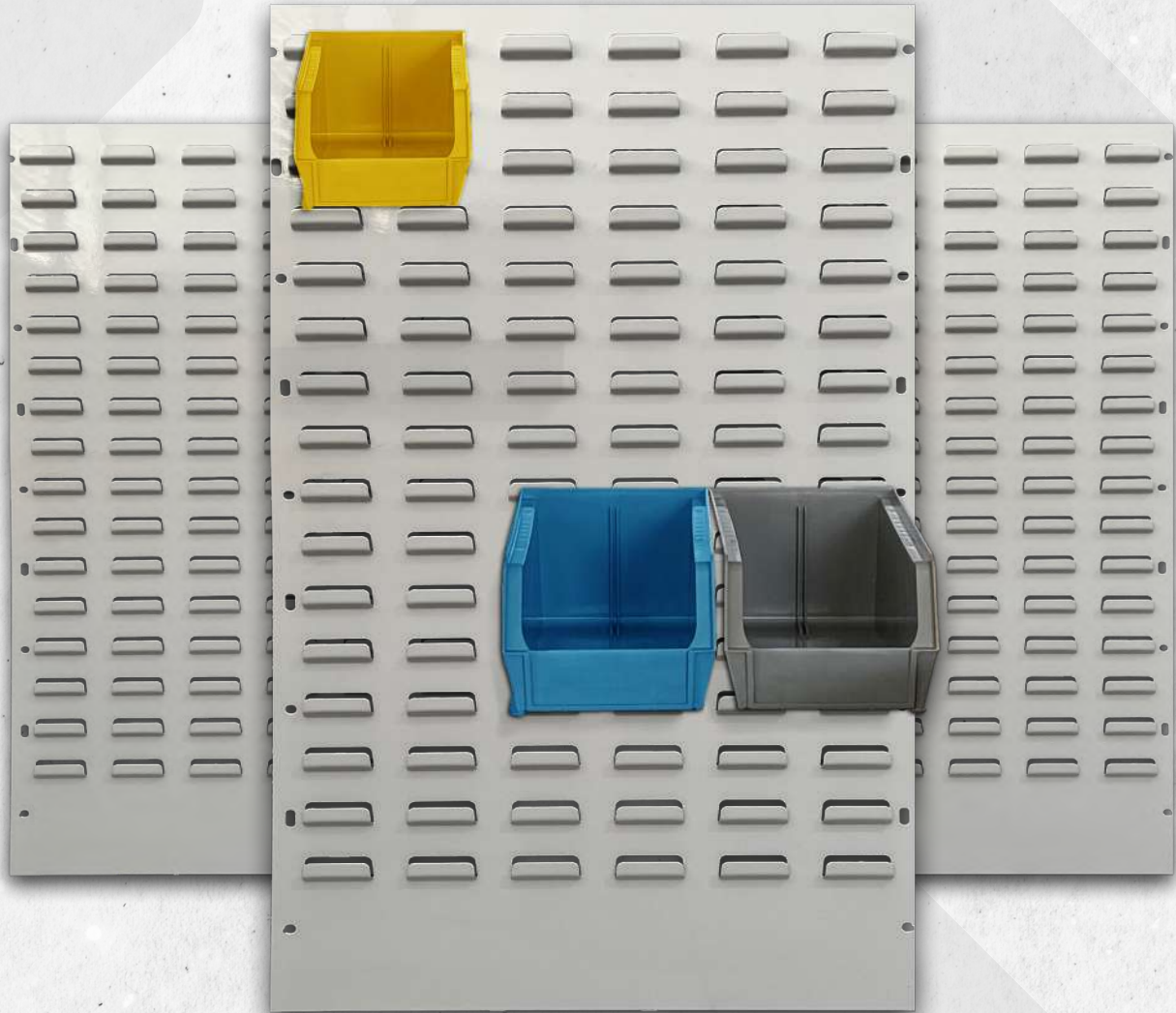

UNIQUE FEATURES

- ✓ Ideal for organizing hand tools
- ✓ Varying bin sizes can be mounted
- ✓ Powder coated steel
- ✓ 5 sizes available
- ✓ Highly resistant to rust

SPECIFICATIONS

SBPANEL0432: (H)432mm x (W)457mm

SBPANEL0914: (H)914mm x (W)457mm

SBPANEL1219: (H)1219mm x (W)457mm

SBPANEL1524: (H)1524mm x (W)457mm

SBPANEL1828: (H)1828mm x (W)457mm

FIRE EXTINGUISHER BOXES



R&B



R&C

UNIQUE FEATURES:

- ✓ Non corrosive and weather resistant
- ✓ Padlock/Security seal tab
- ✓ Inspection window
- ✓ Strong enough to mount on the vehicle with a 9kg bottle



R&R

SPECIFICATIONS

Box weight	4 kg (without content)
Volume	32 L
Material	Polypropylene
Colour	R&B, R&C, R&R

**EXCLUDES
FIRE EXTINGUISHER**

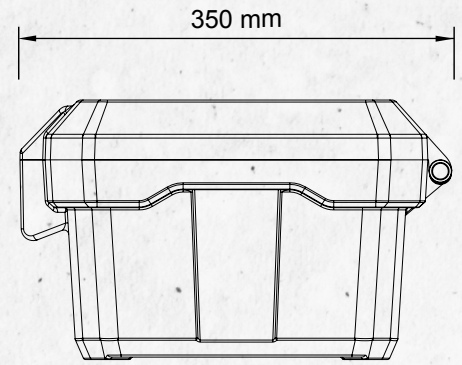
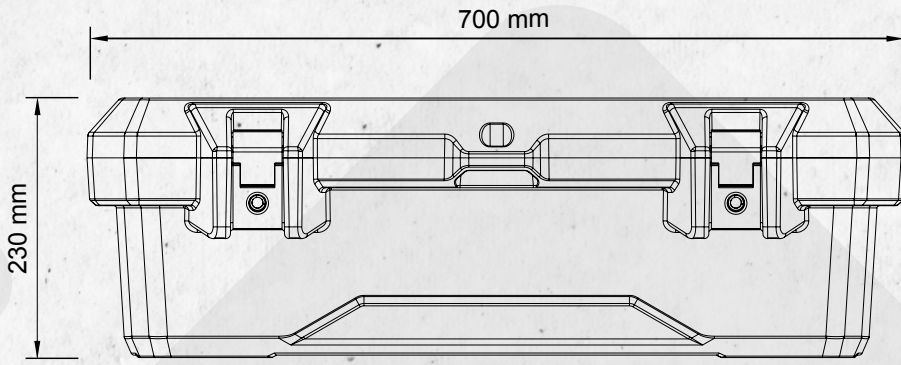

**QUICK ACCESS
& SAFE STORAGE**

**OPEN CRADLE
FIRE BRACKET**

UNIQUE FEATURES:

- ✓ Quick access and easy to use
- ✓ Quick release and durable securing straps
- ✓ Wall or vehicle mountable



MEDICAL BOXES

WALL MOUNTED MEDICAL BOX WITH REMOVABLE INNER BACKPACK



WALL MOUNTED MEDICAL BOX (BOX ONLY)

SPECIFICATIONS

Box weight	4 kg (without content)
Volume	32 L
Material	Polypropylene
Colour	Green base with clear lid or white lid

UNIQUE FEATURES:

- ✓ Durable
- ✓ weather resistant (UV resistant)
- ✓ Padlock tab
- ✓ Wall or vehicle mountable

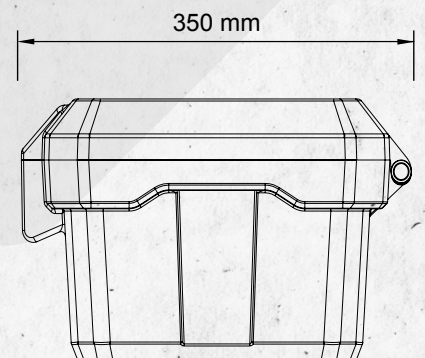
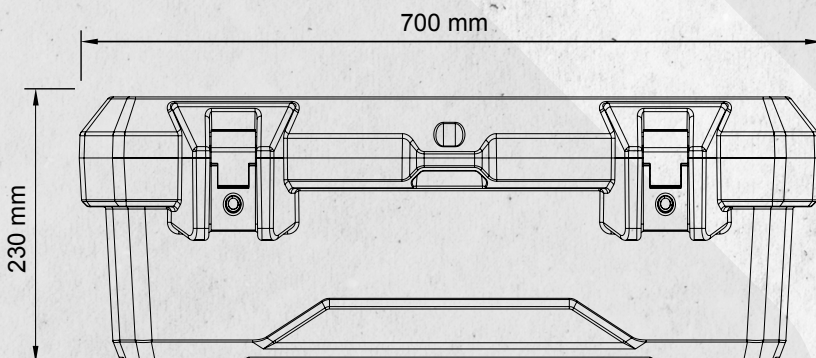

F16 DUST MASK

**IDEAL FOR
PROVIDING PROTECTION
FROM DUST & TOXIC
AIRBORNE HAZARDS**



UNIQUE FEATURES

- ✓ 100% Reusable
- ✓ Replaceable filter
- ✓ Ergonomically designed
- ✓ Available in sizes Medium & Large

SPECIFICATIONS

Material	Soft material
Filter info	ISO 14644-1:2015 certified



STEAM STERILIZATION CONTAINER

- ✓ Polypropylene container to sterilize the mask
- ✓ Suitable for microwaving



COLOUR OPTIONS



3 DIFFERENT STRAP WEAR CONFIGURATIONS



HAND DISPENSER



PUSH



DISPENSE

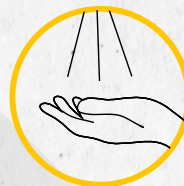

CLEAN



**SANITISER REFILLS
AVAILABLE**

SPECIFICATIONS

Material

ABS

UNIQUE FEATURES

- ✓ 700 ml Refillable bottle
- ✓ Easy push mechanism
- ✓ Easy to mount design.

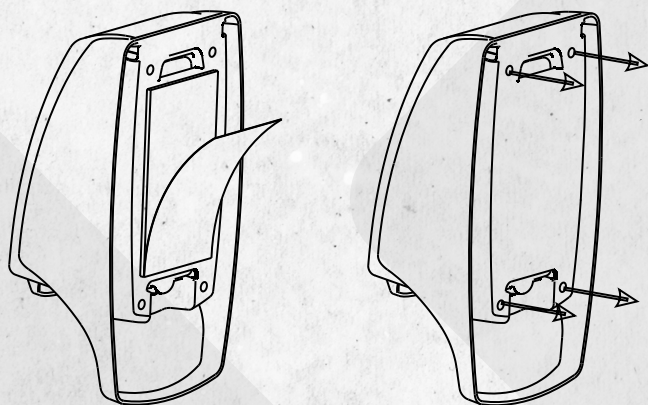

**DOUBLE SIDED TAPE &
SCREW MOUNTING OPTIONS**



CARABINER



UNIQUE FEATURES

- ✓ Easy to clip to belt and/or to hold your keys
- ✓ Built in mini-ruler
- ✓ Built in sharp edge to open boxes/sellotape
- ✓ 2x opening feet to place your phone
- ✓ 5kg carrying capacity

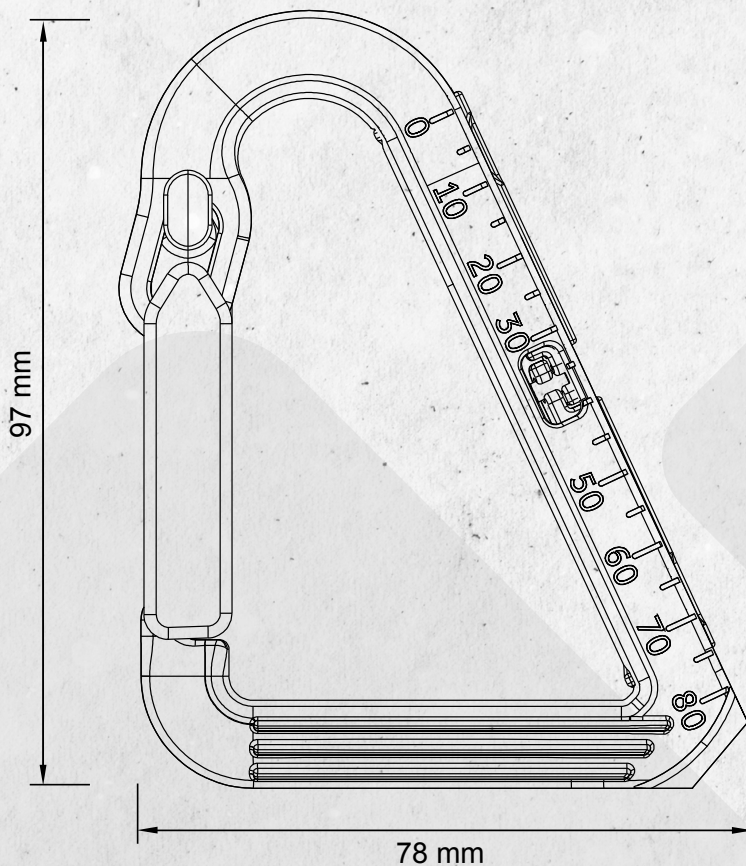

SPECIFICATIONS

Size	97 mm x 78 mm)
Material	Acetal
Colour	Yellow & Black

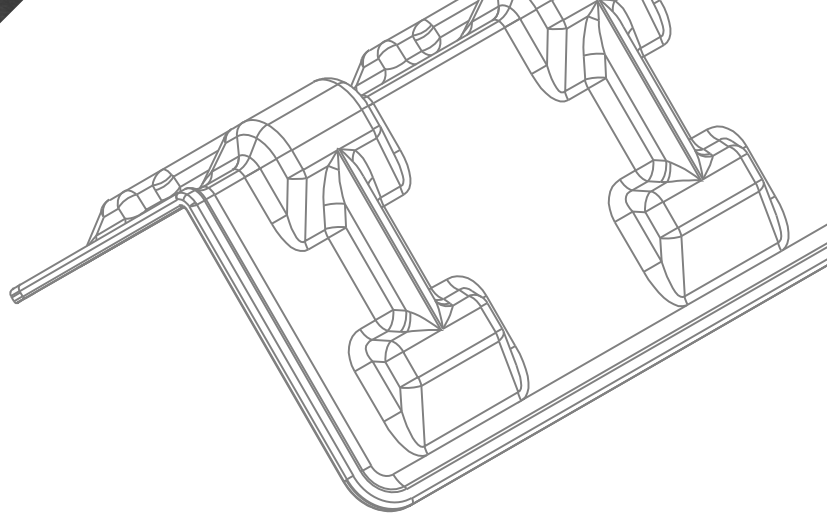

LET'S CONNECT

T: +2711 7084755

E: sales@safeload.co.za

A: 1050 Liner Ave, Corner Zeiss Road, Laser Park, Honeydew,
Johannesburg, South Africa

Opening hours | Mon - Thur 8:00 - 17:00 | Fri 8:00 - 15:00

